

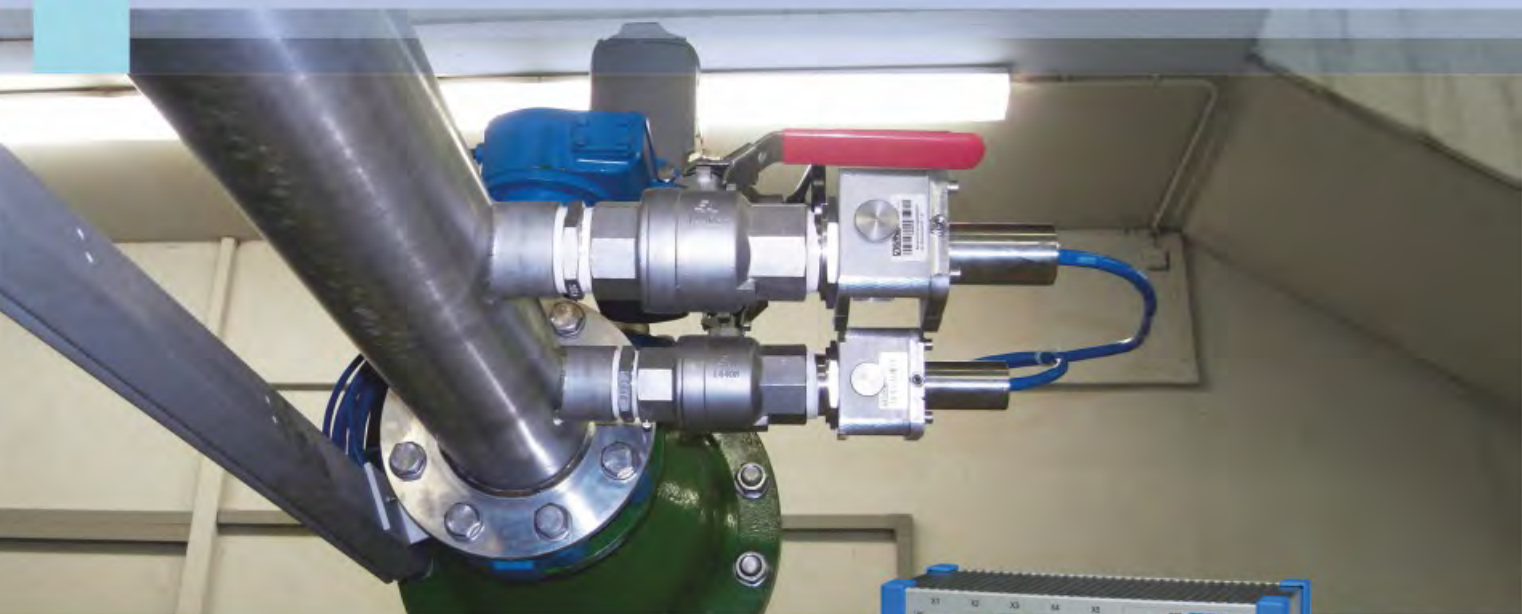

ROYAL Eijkelkamp
Meet the difference

Nijverheidsstraat 9
6987 EN Giesbeek
Nederland
+ 31 313 880 20
info@eijkelkamp.com



NivuFlow 600

**Transit Time Flow Measurement
for clean to slightly
polluted Media in
Full Pipes**

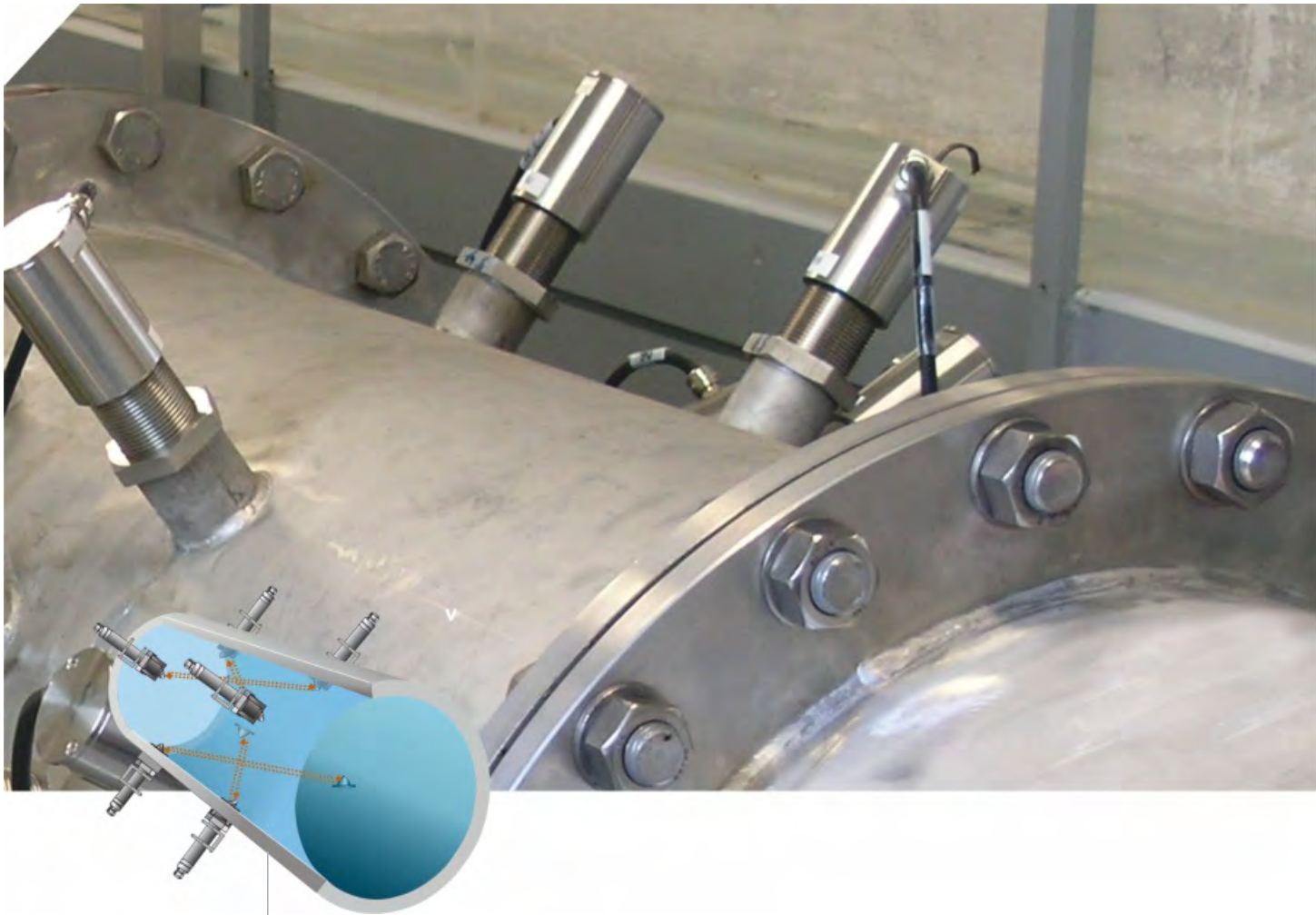

Perfect flow measurement in full pipelines Insert or clamp-on

The NivuFlow 600 system was developed particularly for flow measurement in full pipes. To meet the highest possible accuracy requirements it is possible to utilise up to 32 velocity paths. There are pipe sensors as well as contactless clamp-on sensors available for the measurement system. It is not necessary to interrupt running processes to install both sensor types. The system is suitable for the detection of flow rates in various liquid media covering a wide range of applications.



Flow measurement systems at the highest technical level

The compact enclosure can be easily integrated into switching cabinets saving space thanks to DIN rail mounting. Moreover, the NivuFlow 600 units are available in a special field enclosure for use in rough environmental conditions.

The transmitter's large graphic display allows quick and easy commissioning of the flow metering system. It furthermore provides extended diagnostic options and enables in-depth analyses of running processes on site.

The transmitter software was newly developed from scratch. Using future-proof protocols and versatile options for communication and connections opens a wide variety of options to operators when it comes to integrate the instruments into higher systems such as SCADA or process conducting systems.

Your benefits

- Proven ultrasonic transit time measurement
- Single or multi path measurement up to 32 measurement paths with extension modules
- Insert or clamp-on-sensors available
- Easy installation without interruption of running processes
- Easy setup due to guided sensor positioning
- Intuitive, modern operating concept for quick and easy initial start-up
- IP68 weatherproof version for outdoor use available



Typical Applications

Process water in pipes, cooling water and circulation systems, hydropower plants, penstock monitoring, turbine efficiency monitoring



Transit Time - How the NivuFlow 600 measures

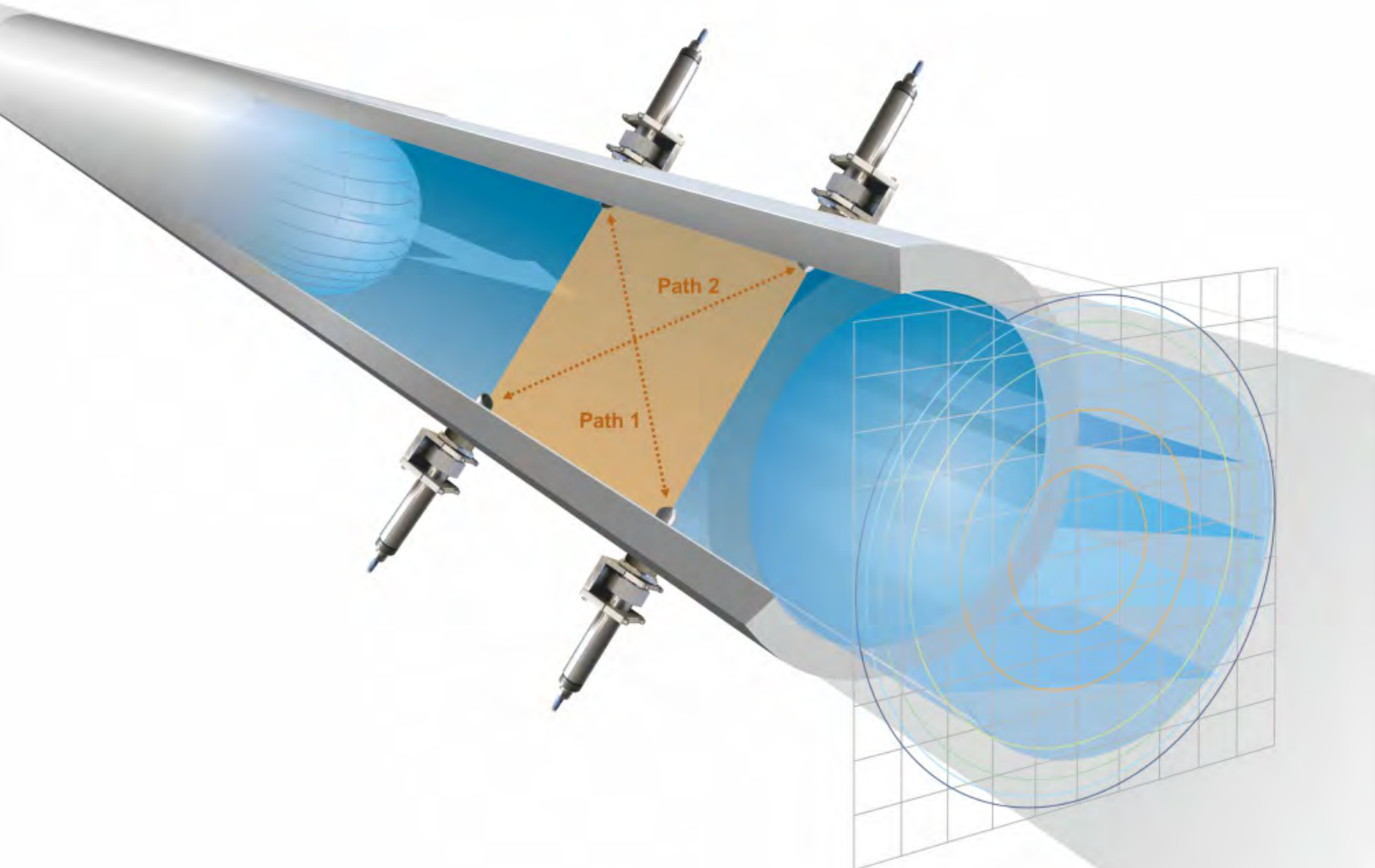

The NivuFlow 600 measurement principle is based on detecting the transit time of ultrasonic signals between two sensors (A and B).

The transit time in flow direction t_1 is shorter than it is against the flow direction t_2 . The difference between both transit times is proportional to the average flow velocity along the measurement path v_m . The system calculates the average cross-sectional area velocity v_A from the path velocity v_m and indicates it directly on the display.

Flow in full pipes is calculated by using the general equation of continuity:

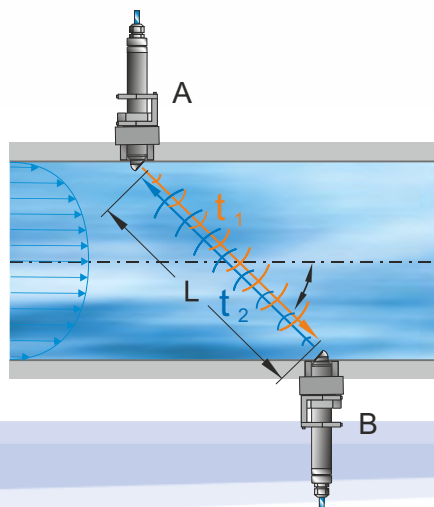

$$Q = A \cdot v_A$$

A = cross-sectional area
 v_A = average flow velocity in cross-sectional area

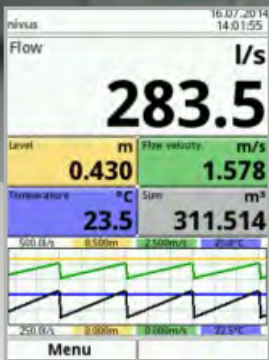

Screen display main screen



Screen display menu

The Nivus Flow 600 Transmitter

The intuitive one-hand operation and the bright high-resolution colour display allow quick, easy and cost-efficient commissioning on site. Additional input devices or software are not required.



Screen display measuring place

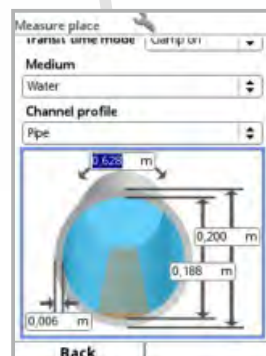

Screen display channel profile





The right sensor for your application

The complete flow measurement system consists of the NivuFlow 600 transmitter and the appropriate sensors for use in full filled pipes.

Your benefits

- Absolutely zero point stable and drift-free sensors
- Low installation expenses through perfectly matched mounting accessories
- Installation under process conditions
- Various sensor constructions guarantee the best solution for each application
- Digital signal transmission for error-free connections over long distances
- WRAS approved pipe sensors available



Clamp-On-Sensor



Wedge sensor



Pipe sensors



Pipe sensor for use in drinking water



Perfect solutions



Turbine intake flow measurement using clamp-on sensors



Nighttime supply flow measurement single path measurement in a full filled pipe



Hydropower plants

On site from anywhere

- Integrated data logger for high data security
- Saved data can be recalled at any time
- Online operation and online setting of parameters (remote control)
- Quick and comprehensive remote diagnostics of entire measurement places

NivuFlow is available as unit for installation in control cabinets or with a robust field enclosure



Field enclosure installation



Transmitter

DIN rail enclosure for easy installation in switching cabinet

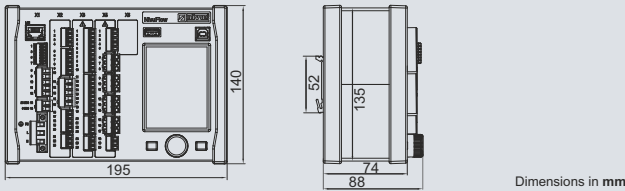

Field enclosure

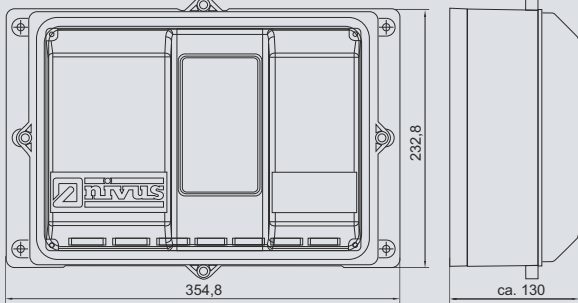

Pipe sensor

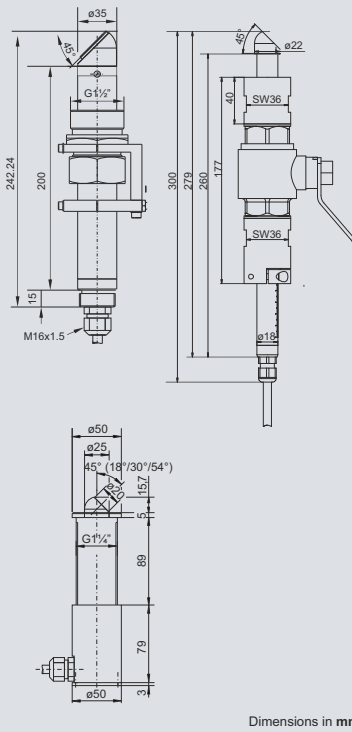

Wedge sensor

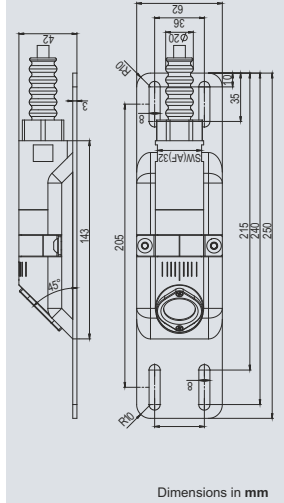

Clamp-on sensors

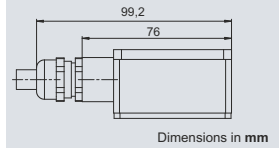

Transmitter

Power supply	100 - 240 V AC, -15 % / +10 %, 47 to 63 Hz or 10 - 35 V DC
Power consumption	1 relay energised, 230 V AC: (rounded) 14 W up to 8 sensors transit time 1 MHz
Enclosure	aluminium, plastic
Weight	approx. 1150 g
Protection	IP20 (control cabinet), IP68 (field enclosure)
Operating temperature	DC: -20°C to +70°C AC: -20°C to +65°C
Storage temperature	-30°C to +80°C
Max. humidity	80%, non-condensing
Display	240 x 320 pixel, 65536 colours
Operation	rotary pushbutton, 2 function keys, menus in English, German, French, and others
Connection	plug with spring cage terminal blocks
Inputs	2x (Type T2) 4-20 mA, with 12 Bit resolution for storage of data from external units, load 91 Ohm, 2 x (Type T2) digital input
Outputs	2 x (Type T2) 0/4-20 mA, load 500 Ohm, 12 Bit resolution 1x (Type T2) bistable relay SPDT, load up to 230 V AC/2 A (cos φ 0.9), minimum switching current 100 mA 1x (Type T2) relay SPDT, load up to 230 V AC/2 A (cos φ 0.9), min. switching current 10 mA
Data memory	1.0 GB internal memory, readout on faceplate via USB stick
Communication	• Modbus TCP via network (LAN/WAN, Internet) • Modbus RTU via RS485 or RS232 • Ethernet TCP/IP
Number of paths	1 up to 4 measurement paths up to 32 measurement paths with NivuFlow Extension Module

Sensor

Measurement principle: Ultrasonic transit time	
Measurement range	flow velocity ±20 m/s (±10 m/s)
Inner pipe diameter	0.1 m to 12 m (DN100 to DN12000) clamp-on: 0.05 m to 6.0 m (DN50 to DN6000)
Measurement uncertainty	flow velocity (v_{average}) ± 0.1 % of measurement value within the path
Measurement frequency	1 MHz
Protection	IP 68
Operating temperature	-20° C to +50° C, clamp-on: -30° C to +80° C
Operating pressure	pipe sensor: max. 16 bar (with retaining element)
Cable length	7/10/15/20/30/50/100 m (extension option: sensors connectable to adapter box, cable length between adapter box and transmitter max. 200 m)
Outer cable diameter	8.5 mm, clamp-on: 7 mm
Sensor types	• pipe sensor with retaining element • wedge sensor with ground plate • Clamp-on-Sensor
Medium contacting materials	• pipe sensor: stainless steel 1.4571, NBR, CFK (Carbon), HDPE, Viton® • wedge sensor: stainless steel 1.4571, CFK (Carbon)

The specifications above are extracts from the complete documentation. You can find the complete specifications on our data sheets.

NIVUS GmbH
Head Office
Im Taele 2
75031 Eppingen, Germany
Tel.: +49(0)7262 9191 0
Fax: +49(0)7262 9191 999
info@nivus.com
www.nivus.de

NIVUS AG
8750 Glarus, Switzerland
Tel.: +41(0)55 6452066
swiss@nivus.com
NIVUS Austria
3382 Loosdorf, Austria
Tel.: +43 (0)2754 5676321
austria@nivus.com

NIVUS Sp. z o.o.
81-212 Gdynia, Poland
Tel.: +48(0)58 7602015
biuro@nivus.pl
NIVUS France
67770 Sessenheim, France
Tel.: +33(0)3 880716 96
info@nivus.fr

NIVUS Ltd.
Head office UK:
David Miles
Tel. +44(0)7834658512
david.miles@nivus.com
Sales office:
Andy Kenworthy
Tel. +44(0)770375 3411
andy.kenworthy@nivus.com

NIVUS Middle East (FZE)
Sharjah Free Zone, UAE
Tel.: +971 6 55 78 224
middle-east@nivus.com
NIVUS Korea Co. Ltd.
Incheon, Korea 21984
Tel.: +82 32 209 8588
korea@nivus.com

NIVUS Chile
Puente Alto, Santiago
Tel.: +562 2266 8119
chile@nivus.com
NIVUS Vietnam
Hanoi
Tel.: +84 12 0446 7724
vietnam@nivus.com